

HOT OIL ROTARY

The BARCO Type C, CF, CS, and CSF Rotary Joints are available in a special design, precision fitted for hot oil/therminol applications. This joint was developed for circulating oil operating at lower and less dangerous pressures than saturated steam systems. Available in 1/2" through 3" sizes, BARCO "Hot Oil" joints are recommended for applications using Mobiltherm 600, Dowtherm, and other heat transfer fluids for circulating systems at temperatures up to +600° F (316° C). The Type C hot oil joint has been field-tested and proven to be the only satisfactory joint among those tested. It is being successfully used on a number of machines designed by several manufacturers of paper, textile, and rubber goods machinery.

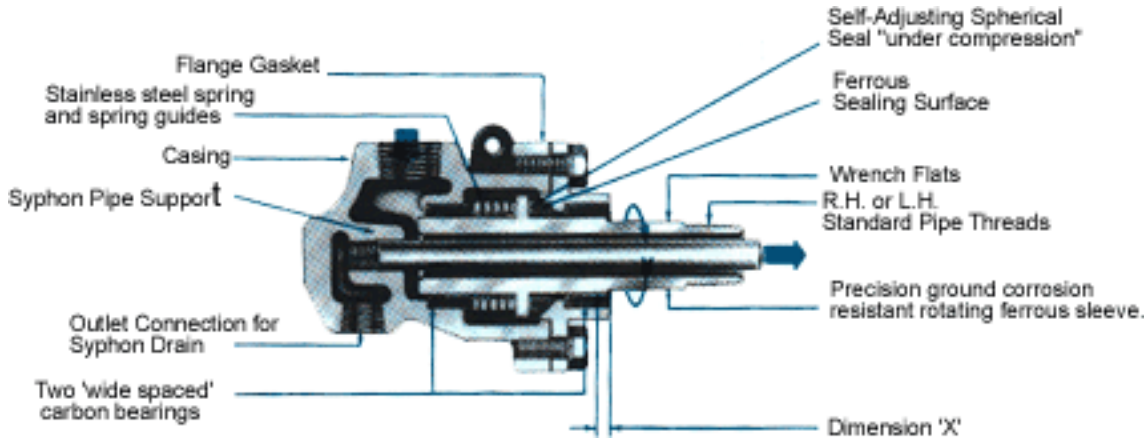

Joint Size	Type C Threaded Sleeve* /with syphon conn.		Type CS Threaded Sleeve* / single flow.		Weight (in lbs.)	Type CF Flanged Sleeve Syphon Conn.	Type CSF Flanged Sleeve Single Flow.	Weight (in lbs.)
	Assembly Numbers		Assembly Numbers			Assembly Number	Assembly Number	
	Left Hand	Right Hand	Left Hand	Right Hand		Assembly Number	Assembly Number	
1/2	BC54000-08-21	BC54000-08-20	BC54100-08-21	BC54100-08-20	3.5	-	-	-
3/4	BC54000-12-21	BC54000-12-20	BC54100-12-21	BC54100-12-20	4.5	-	-	-
1	BC54000-16-21	BC54000-16-20	BC54100-16-21	BC54100-16-20	5.5	BC54000-16-30	BC54100-16-30	6.5
1-1/4	BC54000-20-21	BC54000-20-20	BC54100-20-21	BC54100-20-20	12	BC54000-20-30	BC54100-20-30	13
1-1/2	BC54000-24-21	BC54000-24-20	BC54100-24-21	BC54100-24-20	15	BC54000-24-30	BC54100-24-30	16.5
2	BC54000-32-21	BC54000-32-20	BC54100-32-21	BC54100-32-20	26	BC54000-32-30	BC54100-32-30	29
2-1/2	BC54000-40-21	BC54000-40-20	BC54100-40-21	BC54100-40-20	35	BC54000-40-30	BC54100-40-30	37
3	BC54000-48-21	BC54000-48-20	BC54100-48-21	BC54100-48-20	44	BC54000-48-30	BC54100-48-30	50
For dimensions see Type C and CS and Type CF and CSF * Joints are available with JIS and /or BSP threads on sleeve.								

Preventive Maintenance

By measuring dimension 'X' (from step on sleeve to end of cap) and referring to the table on the C and CS page visual inspection periodically can determine seal wear.

When measured dimension exceeds 'X' dimension, hot oil repair kits may be ordered from your local BARCO distributor.

Many of the present oils used tend to "coke" at high temperatures and deposit material which settles in the joint. The joint must be periodically cleaned to remove this residue. In addition, hot spots in the joint may generate this material. BARCO recommends a 40-60 micron filter be installed upstream from the rotary joint to collect this residue and protect the joint.

Note

Joints are available for applications exceeding +600° F. Contact BARCO for details.