

SFL ROTARY UNIONS

Bearing Supported Style

The BARCO SFL Rotary Union is designed to supply coolant to high speed, multi-spindle heads and independent box spindles on automotive transfer lines. Dial machines, grinding machines and gun drills are also potential applications.

Our state-of-the-art silicon carbide seals and the specially protected sealed-for-life bearings make this union ideal for new installations as well as for retrofits of other manufacturers coolant unions. The BARCO SFL is the only rotary union that's color coded to ensure choosing the correct union in replacement situations.

Special Design Features

- Unique, sealed-for-life bearing design.
- Dual oil lip-seals protect bearings from both sides - prevent grease washout.
- Exclusive, large double row angular contact bearings in a compact, rigid design with tolerance to hose side loading.
- Silicon carbide to silicon carbide mechanical seals.
- Color coded housing identifies mounting thread.
- Wrench flats fit standard US and metric tools.
- Directly interchangeable with virtually any OEM self-supported rotary union.

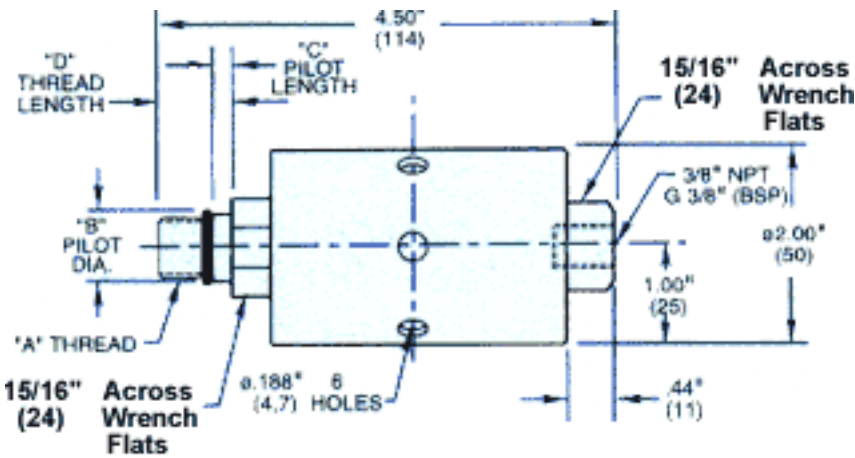

STRAIGHT MODEL

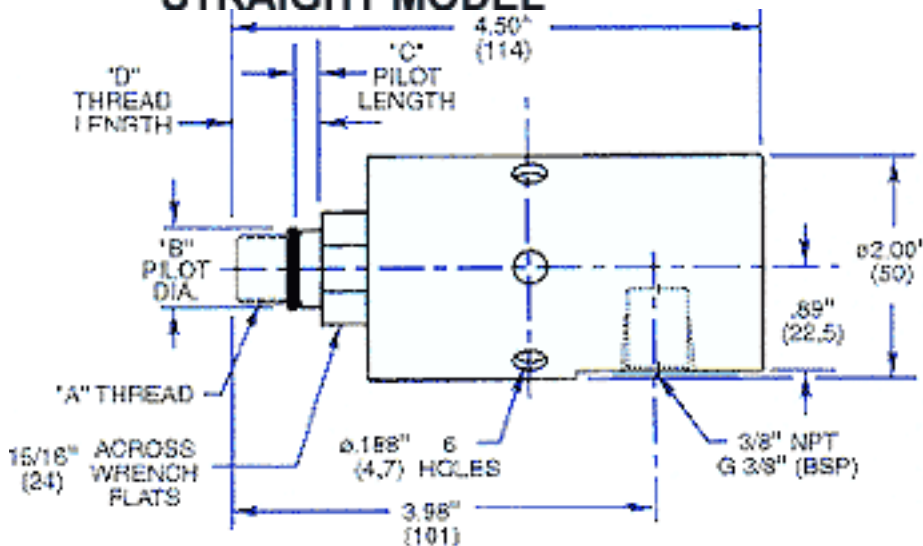

90° Model

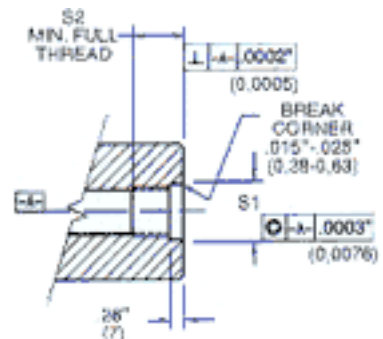

SPINDLE END DETAIL

Specifications for NPT

Style NPT	Part Number	Color	"A" Thread	"B" Pilot Dia.	"C" Pilot Length	"D" Thread Length	S1	S2 min.
STR.	BC-54913-06-06	Red	M12 x 1.25 LH	.5300"-.5305" (13.462-13.475)	.188" (4.78)	.750" (19)	.5307"-.5311" (13.479-13.490)	.81* (21)
90°	BC-54909-06-06							
STR.	BC-54915-06-06	Black	M16 x 1.5 LH	.7078"-.7083" (17.978-17.993)	.188" (4.78)	.621" (15.7)	.7085" - .7087" (17.995-18.000)	.67* (17)
90°	BC-54903-06-06							
STR.	BC-54917-06-06	Gold	5/8"-18 UNF LH	.6550"-.6555" (16.637-16.650)	.188" (4.78)	.750" (19)	.6556" - .6560" (16.652-16.663)	.81* (21)
90°	BC-54905-06-06							
Special threads available. Contact BARCO								

Specifications for BSP

Style BSP	Part Number	Color	"A" Thread	"B" Pilot Dia.	"C" Pilot Length	"D" Thread Length	S1	S2 min.
STR.	BC-54949-06-06	Red	M12 x 1.25 LH	.5300"-.5305" (13.462-13.475)	.188" (4.78)	.750" (19)	.5307"-.5311" (13.479-13.490)	.81* (21)
90°	BC-54939-06-06							
STR.	BC-54943-06-06	Black	M16 x 1.5 LH	.7078"-.7083" (17.978-17.993)	.188" (4.78)	.621" (15.7)	.7085" - .7087" (17.995-18.000)	.67* (17)
90°	BC-54933-06-06							
STR.	BC-54945-06-06	Gold	5/8"-18 UNF LH	.6550"-.6555" (16.637-16.650)	.188" (4.78)	.750" (19)	.6556" - .6560" (16.652-16.663)	.81* (21)
90°	BC-54935-06-06							