

BARCO SERIES **SFL**

Machine Tool Coolant Rotary Union

Bearing Supported Style

Sealed-For-Life
Maintenance-Free
Lubed-For-Life

Special Design Features

- Unique, sealed-for-life bearing design.
- Dual oil lip-seals protect bearings from both sides – prevent grease wash-out.
- Exclusive, large double-row angular contact bearings in a compact, rigid design with high tolerance to hose side-loading.
- Silicon carbide-to-silicon carbide mechanical seals.
- Color coded housing identifies mounting thread.
- Wrench-flats fit standard U.S. and metric tools.
- Directly interchangeable with virtually any OEM self-supported rotary union.

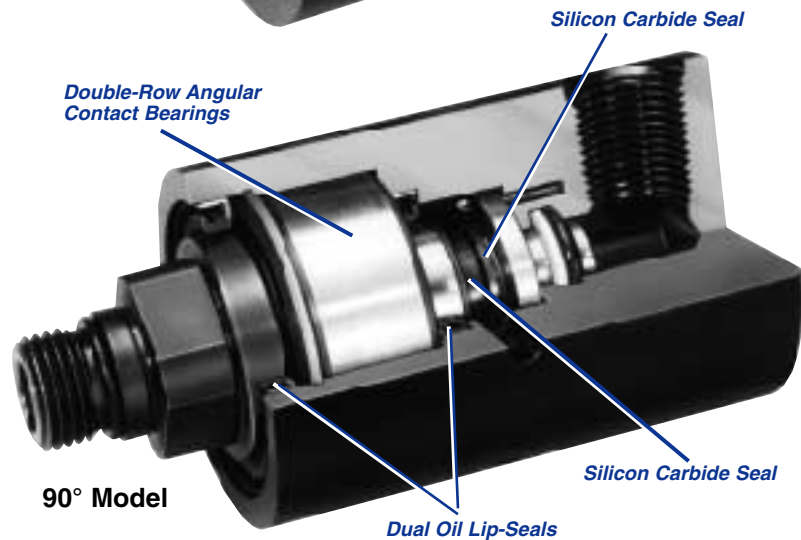

The Barco SFL Rotary Union is designed to supply coolant to high-speed, multi-spindle heads and independent box spindles on automotive transfer lines. Dial machines, grinding machines and gun-drills are also potential applications.

Our state-of-the-art silicon carbide seals and the specially protected sealed-for-life bearings make this union ideal for new installations as well as for retrofits of other manufacturers' coolant unions. The Barco SFL is the only rotary union that's color coded to assure choosing the correct union in replacement situations.

Operating Data

Max. Pressure	1500 PSI	105 BAR
Max. Speed	8500 RPM	8500/MIN

Do not run max speed and pressure simultaneously.
Contact Barco. **Do not run dry.**

RECOMMENDED HOSE SPECIFICATIONS

SAE NO: 100R1, Type AT
(3/8" Single Wire Braided Hose)

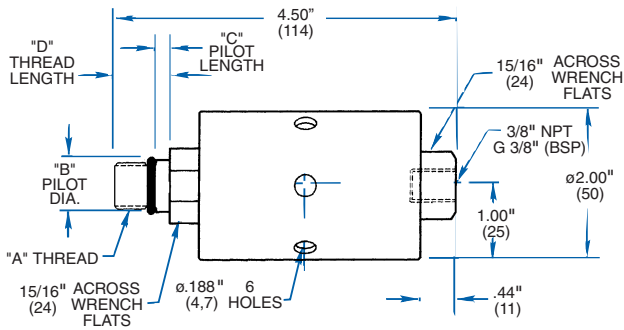

STRAIGHT MODEL

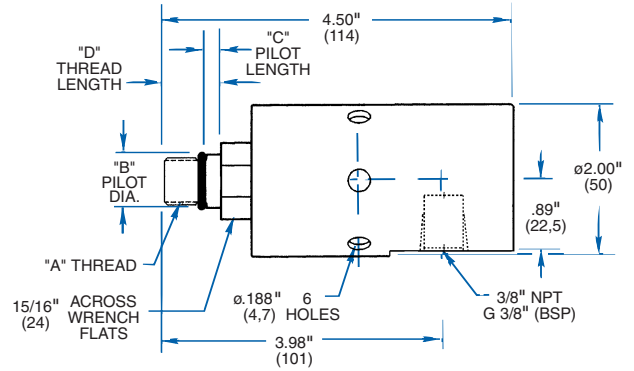

90° MODEL

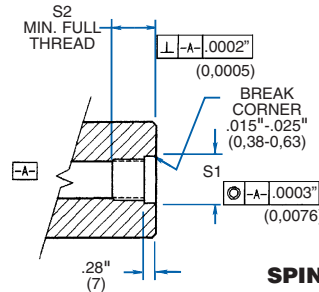

SPINDLE END DETAIL

Specifications for NPT

STYLE NPT	PART NUMBER	COLOR	"A" (1) THREAD	"B" PILOT DIA.	"C" PILOT LENGTH	"D" THREAD LENGTH	S1	S2 MIN
STR.	BC-54913-06-06	RED	M12 X 1.25 LH	.5300"-.5305" (13,462 - 13,475)	.188" (4,78)	.750" (19)	.5307" - .5311" (13,479 - 13,490)	.81" (21)
90°	BC-54909-06-06							
STR.	BC-54915-06-06	BLACK	M16 X 1.5 LH	.7078"-.7083" (17,978 - 17,993)	.188" (4,78)	.621" (15,7)	.7085" - .7087" (17,995 - 18,000)	.67" (17)
90°	BC-54903-06-06							
STR.	BC-54917-06-06	GOLD	5/8" - 18 UNF LH	.6550"-.6555" (16,637 - 16,650)	.188" (4,78)	.750" (19)	.6556" - .6560" (16,652 - 16,663)	.81" (21)
90°	BC-54905-06-06							

(1) Special threads available. Contact Barco.

Specifications for BSP

STYLE BSP	PART NUMBER	COLOR	"A" (1) THREAD	"B" PILOT DIA.	"C" PILOT LENGTH	"D" THREAD LENGTH	S1	S2 MIN
STR.	BC-54949-06-06	RED	M12 X 1.25 LH	.5300"-.5305" (13,462 - 13,475)	.188" (4,78)	.750" (19)	.5307" - .5311" (13,479 - 13,490)	.81" (21)
90°	BC-54939-06-06							
STR.	BC-54943-06-06	BLACK	M16 X 1.5 LH	.7078"-.7083" (17,978 - 17,993)	.188" (4,78)	.621" (15,7)	.7085" - .7087" (17,995 - 18,000)	.67" (17)
90°	BC-54933-06-06							
STR.	BC-54945-06-06	GOLD	5/8" - 18 UNF LH	.6550"-.6555" (16,637 - 16,650)	.188" (4,78)	.750" (19)	.6556" - .6560" (16,652 - 16,663)	.81" (21)
90°	BC-54935-06-06							

(1) Special threads available. Contact Barco.

Barco International
1100 Alexander Court
Cary, IL 60013-1892
Phone: (847) 516-0900
Fax: (847) 516-5590



A DIVISION OF MARISON INDUSTRIES