

BARCO SERIES TYPE "CS" & "CSF"

Steam Mono-flow

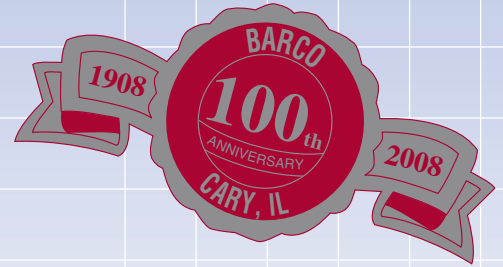

BC-54100 SERIES

Special Design Features

- **Two widely spaced Carbon Bearings** provides greater support to the syphon pipe and hoses.
- **Carbon Seal placed under compression** add strength and shock resistance. Joints lasts longer.
- **External seal wear indicator** allows for planned maintenance reducing expensive downtime.
- **Hardened sleeve and nickel plated end cap** provide exceptional life at high pressure.

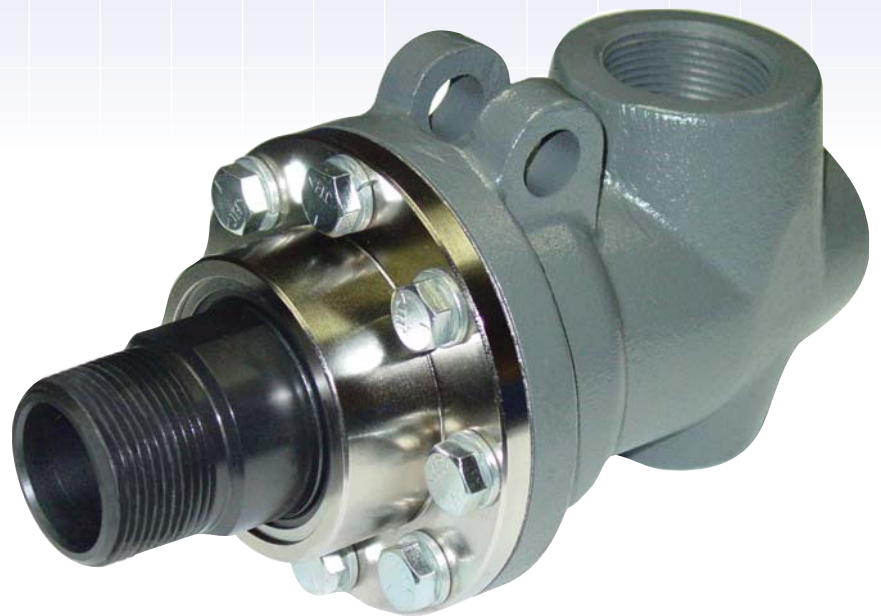

Sizes 1/2" to 3"

Type "CS" Ferrous Trim Rotary Joints are ideal for a wide range of applications using steam. These joints feature an iron casing, ferrous sleeve and end cap, stainless steel spring and spring guides.

The high density carbon seal under compression and widely spaced bearing surfaces assure exceptionally long service life without lubrication. A key maintenance feature is the external seal wear indicator.

Operating Parameters:

Temperature:	+406°F (+208°C)
Pressure Rating:	
Sizes 1/2" to 1-1/2"	250 psi (17.2 BAR)
Sizes 2" to 3"	225 psi (15.5 BAR)

TYPE "CS" & "CSF"



Ferrous Trim Construction
Recommended for higher pressure steam
to 250 psi (17.2 BAR)

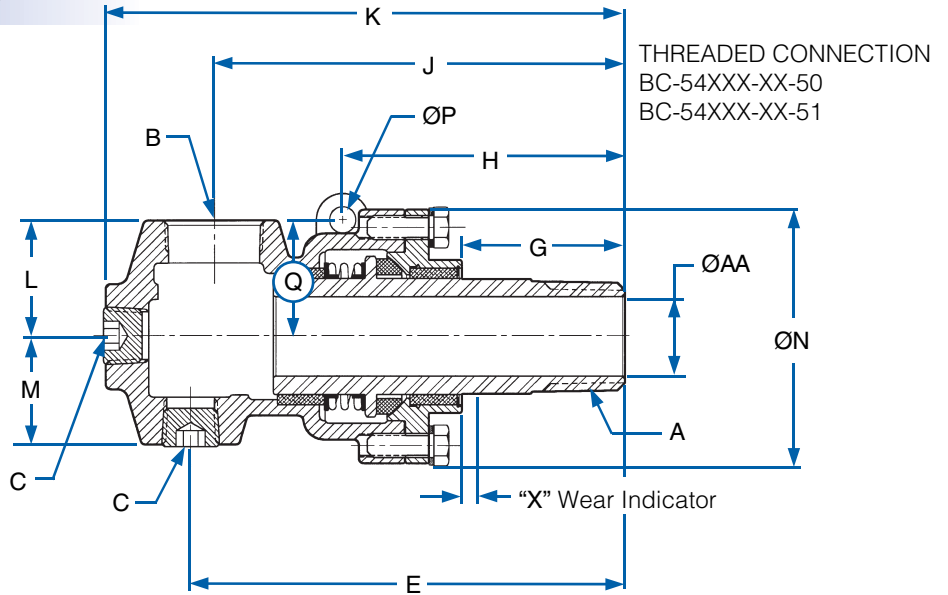

For BSPT threads:

Add a "B" to the end of the part number.

Example: BC-54100-08-50B

Joint Size	Ferrous Trim Part Number	A NPT	B NPT	øAA	C NPT	E	G	H	J	K	L	M
1/2"	BC-54100-08-50	1/2" R.H.	1/2"	Ø.50"	1/4"	5.37"	1.73"	—	4.54"	5.87"	1.62"	1.16"
	BC-54100-08-51	1/2" L.H.	1/2"	Ø.50"	1/4"	5.37"	1.73"	—	4.54"	5.87"	1.62"	1.16"
3/4"	BC-54100-12-50	3/4" R.H.	3/4"	Ø.75"	1/2"	5.16"	1.68"	—	4.54"	6.17"	1.75"	1.25"
	BC-54100-12-51	3/4" L.H.	3/4"	Ø.75"	1/2"	5.16"	1.68"	—	4.54"	6.17"	1.75"	1.25"
1"	BC-54100-16-50	1" R.H.	1"	Ø1.00"	1/2"	5.96"	2.03"	4.01"	5.21"	7.01"	2.06"	1.25"
	BC-54100-16-51	1" L.H.	1"	Ø1.00"	1/2"	5.96"	2.03"	4.01"	5.21"	7.01"	2.06"	1.25"
	BC-54100-16-60	CF	1"	Ø1.00"	1/2"	6.69"	2.77"	4.75"	5.94"	7.75"	2.06"	1.25"
	BC-54100-16-62	QR	1"	Ø1.00"	1/2"	6.70"	2.78"	4.76"	5.95"	7.76"	2.06"	1.25"
1 1/4"	BC-54100-20-50	1 1/4" R.H.	1 1/4"	Ø1.25"	3/4"	6.99"	1.89"	4.37"	6.68"	8.60"	2.19"	1.78"
	BC-54100-20-51	1 1/4" L.H.	1 1/4"	Ø1.25"	3/4"	6.99"	1.89"	4.37"	6.68"	8.60"	2.19"	1.78"
	BC-54100-20-62	QR	1 1/4"	Ø1.25"	3/4"	8.55"	3.45"	5.93"	8.24"	10.16"	2.19"	1.78"
1 1/2"	BC-54100-24-50	1 1/2" R.H.	1 1/2"	Ø1.50"	3/4"	7.48"	2.12"	4.72"	7.04"	9.03"	2.44"	2.06"
	BC-54100-24-51	1 1/2" L.H.	1 1/2"	Ø1.50"	3/4"	7.48"	2.12"	4.72"	7.04"	9.03"	2.44"	2.06"
	BC-54100-24-60	CF	1 1/2"	Ø1.50"	3/4"	8.89"	3.53"	6.13"	8.45"	10.45"	2.44"	2.06"
	BC-54100-24-62	QR	1 1/2"	Ø1.50"	3/4"	8.89"	3.53"	6.13"	8.45"	10.45"	2.44"	2.06"
2"	BC-54100-32-50	2" R.H.	2"	Ø1.88"	1 1/4"	8.62"	2.19"	5.01"	8.06"	10.63"	2.75"	2.56"
	BC-54100-32-51	2" L.H.	2"	Ø1.88"	1 1/4"	8.62"	2.19"	5.01"	8.06"	10.63"	2.75"	2.56"
	BC-54100-32-60	CF	2"	Ø1.88"	1 1/4"	10.09"	3.66"	6.48"	9.53"	12.10"	2.75"	2.56"
	BC-54100-32-62	QR	2"	Ø1.88"	1 1/4"	9.71"	3.28"	6.10"	9.15"	11.72"	2.75"	2.56"
2 1/2"	BC-54100-40-50	2 1/2" R.H.	2 1/2"	Ø2.25"	1 1/4"	10.14"	2.91"	6.33"	9.76"	12.45"	3.00"	2.50"
	BC-54100-40-51	2 1/2" L.H.	2 1/2"	Ø2.25"	1 1/4"	10.14"	2.91"	6.33"	9.76"	12.45"	3.00"	2.50"
	BC-54100-40-60	CF	2 1/2"	Ø2.25"	1 1/4"	10.09"	3.66"	6.48"	9.53"	12.10"	3.00"	2.50"
	BC-54100-40-62	QR	2 1/2"	Ø2.25"	1 1/4"	10.77"	3.54"	6.96"	10.39"	13.08"	3.00"	2.50"
3"	BC-54100-48-50	3" R.H.	3"	Ø2.88"	1 1/2"	10.86"	3.05"	6.60"	10.67"	13.04"	3.62"	2.88"
	BC-54100-48-51	3" L.H.	3"	Ø2.88"	1 1/2"	10.86"	3.05"	6.60"	10.67"	13.04"	3.62"	2.88"
	BC-54100-48-60	CF	3"	Ø2.88"	1 1/2"	11.35"	3.55"	7.10"	11.16"	13.53"	3.62"	2.88"
	BC-54100-48-62	QR	3"	Ø2.88"	1 1/2"	11.36"	3.55"	7.10"	11.16"	13.54"	3.62"	2.88"

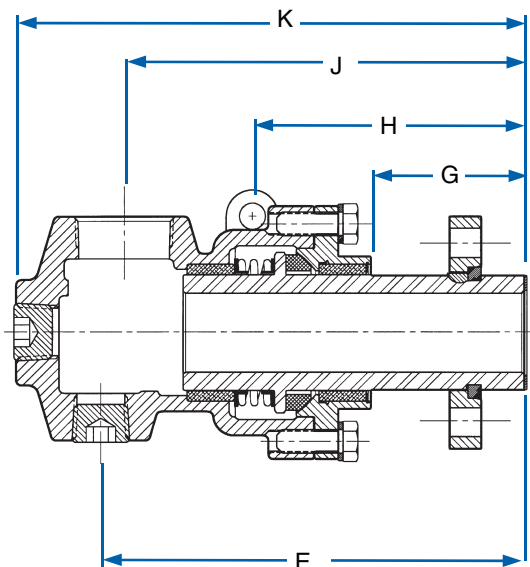

"CF" CONNECTION
BC-54XXX-XX-60

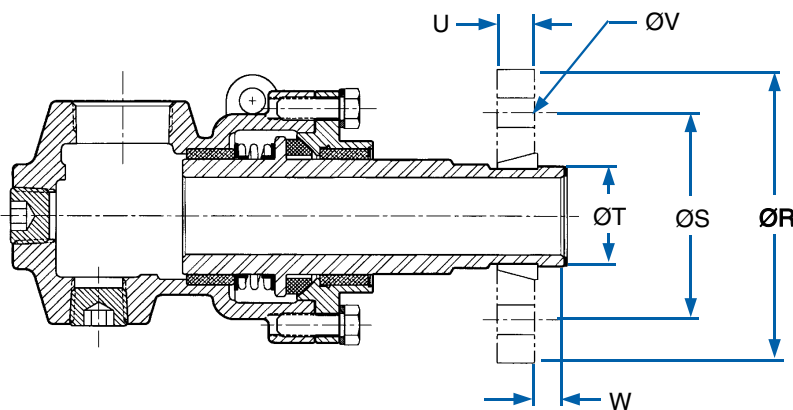

QUICK RELEASE CONNECTION
BC-54XXX-XX-62

ØN	ØP	Torque Rod O.D. Max.	Q	ØR	ØS	ØT	U	4X ØV	W	"X"	Weight	Joint Size
Ø3.00"	—	—	—	—	—	—	—	—	—	.19"	3.5 lbs	1/2"
Ø3.00"	—	—	—	—	—	—	—	—	—	.19"	3.5 lbs	
Ø3.38"	—	—	—	—	—	—	—	—	—	.19"	5 lbs.	3/4"
Ø3.38"	—	—	—	—	—	—	—	—	—	.19"	5 lbs.	
Ø3.62"	Ø.50"	Ø.38"	1.75"	—	—	—	—	—	—	.25"	6 lbs.	1"
Ø3.62"	Ø.50"	Ø.38"	1.75"	—	—	—	—	—	—	.25"	6 lbs.	
Ø3.62"	Ø.50"	Ø.38"	1.75"	Ø3.88"	Ø2.75"	Ø1.399"-1.401"	.75"	Ø.56"	1.092"	.25"	9 lbs.	1"
Ø3.62"	Ø.50"	Ø.38"	1.75"	Ø5.00"	Ø3.12"	Ø1.276"-1.278"	.56"	Ø.56"	.438"	.25"	9 lbs.	
Ø4.38"	Ø.62"	Ø.50"	2.09"	—	—	—	—	—	—	.25"	13 lbs	1 1/4"
Ø4.38"	Ø.62"	Ø.50"	2.09"	—	—	—	—	—	—	.25"	13 lbs	
Ø4.38"	Ø.62"	Ø.50"	2.09"	Ø5.50"	Ø3.50"	Ø1.620"-1.622"	.62"	Ø.56"	.50"	.25"	18 lbs.	1 1/2"
Ø4.75"	Ø.62"	Ø.50"	2.26"	—	—	—	—	—	—	.25"	15 lbs	
Ø4.75"	Ø.62"	Ø.50"	2.26"	—	—	—	—	—	—	.25"	15 lbs	1 1/2"
Ø4.75"	Ø.62"	Ø.50"	2.26"	Ø4.88"	Ø3.62"	Ø2.091"-2.093"	.75"	Ø.69"	1.092"	.25"	19 lbs	
Ø4.75"	Ø.62"	Ø.50"	2.26"	Ø5.50"	Ø3.88"	Ø1.872"-1.870"	.69"	Ø.56"	.50"	.25"	19 lbs.	2"
Ø6.00"	Ø.62"	Ø.50"	2.76"	—	—	—	—	—	—	.31"	26 lbs	
Ø6.00"	Ø.62"	Ø.50"	2.76"	—	—	—	—	—	—	.31"	26 lbs	2"
Ø6.00"	Ø.62"	Ø.50"	2.76"	Ø5.50"	Ø4.25"	Ø2.714"-2.716"	.75"	Ø.69"	1.092"	.31"	31 lbs	
Ø6.00"	Ø.62"	Ø.50"	2.76"	Ø6.81"	Ø4.75"	Ø2.318"-2.320"	.75"	Ø.56"	.625"	.31"	34 lbs.	2 1/2"
Ø6.75"	Ø.75"	Ø.62"	3.06"	—	—	—	—	—	—	.25"	33 lbs.	
Ø6.75"	Ø.75"	Ø.62"	3.06"	—	—	—	—	—	—	.25"	33 lbs.	2 1/2"
Ø6.75"	Ø.75"	Ø.62"	3.06"	Ø5.88"	Ø4.62"	Ø3.089"-3.091"	.75"	Ø.75"	1.092"	.25"	40 lbs	
Ø6.75"	Ø.75"	Ø.62"	3.06"	Ø6.75"	Ø4.75"	Ø2.838"-2.840"	.88"	Ø.56"	.75"	.25"	42 lbs.	3"
Ø7.88"	Ø.94"	Ø.75"	3.62"	—	—	—	—	—	—	.25"	45 lbs.	
Ø7.88"	Ø.94"	Ø.75"	3.62"	—	—	—	—	—	—	.25"	45 lbs.	3"
Ø7.88"	Ø.94"	Ø.75"	3.62"	Ø6.50"	Ø5.25"	Ø3.714"-3.716"	.75"	Ø.69"	1.092"	.25"	50 lbs	
Ø7.88"	Ø.94"	Ø.75"	3.62"	Ø8.00"	Ø6.75"	Ø3.430"-3.732"	.94"	Ø.69"	.88"	.25"	57 lbs.	3"

CF Connection

BC-54XXX-XX-60

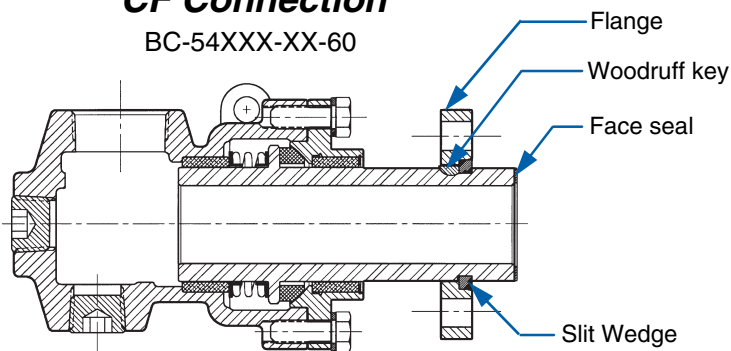

Quick Release Connection

BC-54XXX-XX-62

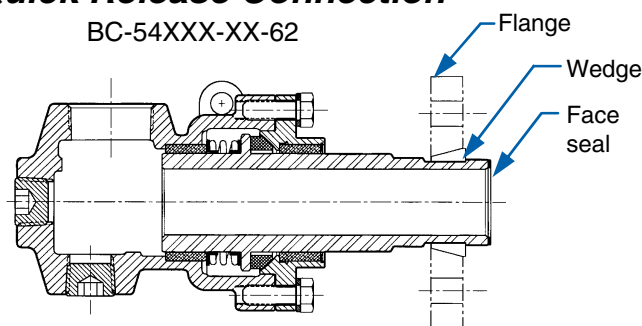

Journal Dimensions

Joint size	CF Connection		Quick Release Connection	
	ØA	B	ØA	B
1"	Ø1.408"-1.406"	1.052"	Ø1.283"-1.279"	.312"
1 1/2"	Ø2.099"-2.096"	1.052"	Ø1.877"-1.873"	.375"
2"	Ø2.724"-2.721"	1.052"	Ø2.325"-2.321"	.500"
2 1/2"	Ø3.099"-3.096"	1.052"	Ø2.845"-2.841"	.625"
3"	Ø3.724"-3.721"	1.052"	Ø3.439"-3.435"	.875"

Quick Release Flanges and split wedges are available. Contact Barco for more information.

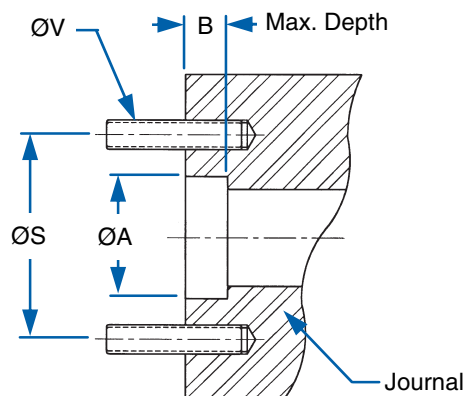

Repair Kits

Joint Size	Part Number
1/2"	10-27274-00
3/4"	10-27275-00
1"	10-27276-00
1 1/4"	10-27277-00
1 1/2"	10-27278-00
2"	10-27279-00
2 1/2"	10-27280-00
3"	10-27281-00

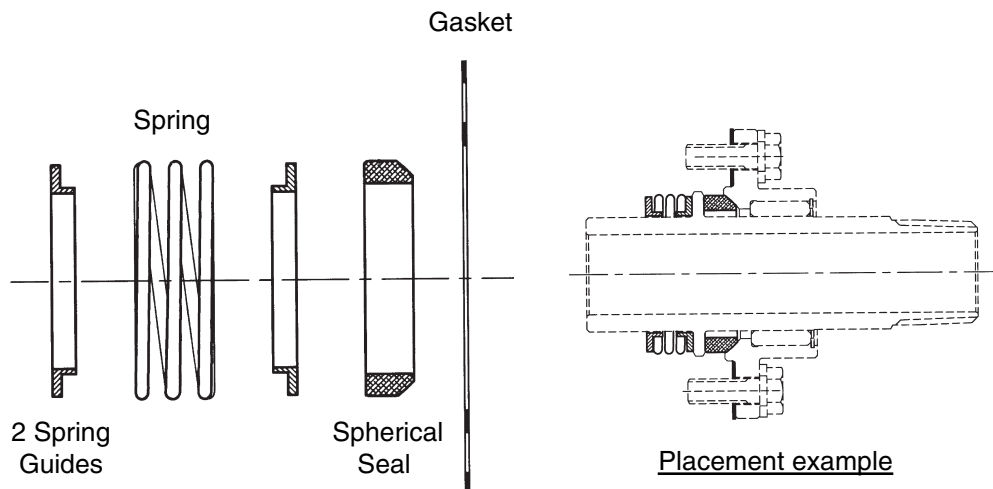

Barco International
1100 Alexander Court
Cary, IL 60013-1892
Phone: (847) 516-0900
Fax: (847) 516-5590



A DIVISION OF MARISON INDUSTRIES

Distributed By: