



Type "C" Installation Procedures

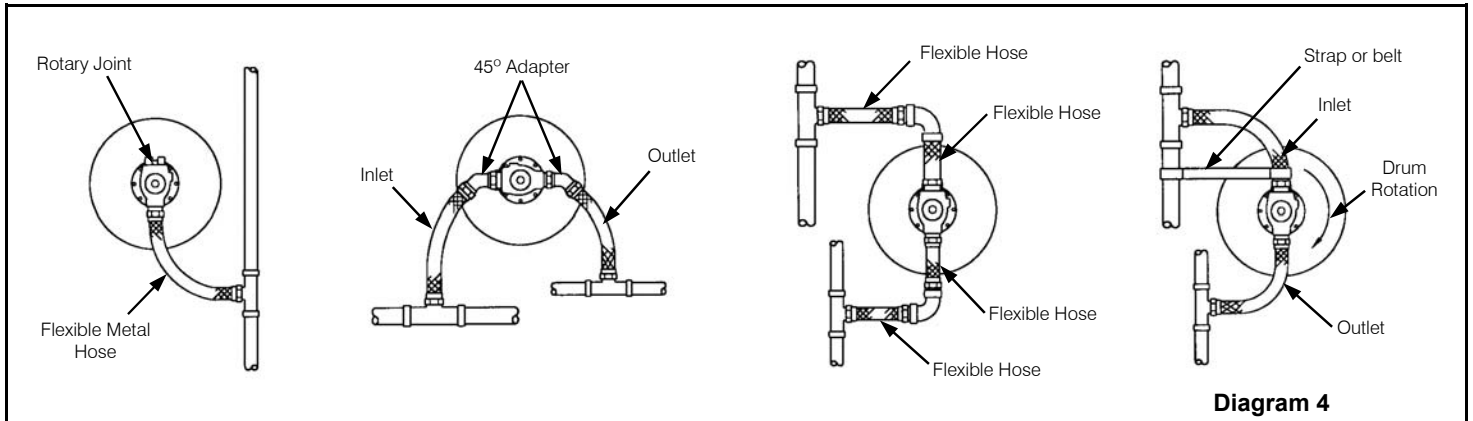

Diagram 4

BARCO Rotary Joints can usually be easily installed. By following the instructions outlined here, the full potential of the rotary joint for long trouble-free service will be assured.

Connecting hoses must be installed with the hose bent from 45° to 90°, to avoid loading the joint with stresses from hose lengths that are too short. A straight hose will not provide flexibility and may contract under pressure producing a side load on the joint.

The hose connections to the joint, from the steam or other fluid header, should be installed with care. Hose may be either of the flexible metal type or the newer Teflon type. Rubber hose is recommended only for low temperature water service.

The hose should be long enough to avoid kinking. A kinked hose will usually leak and fail at the kink in a relatively short time. Elbow fittings and elbow adapters can be used to

reduce the amount of bend required in the hose and are recommended for use whenever the hose is bent too sharply, or tighter than the bend radii recommended for the particular size, see Table 1.

Torque restraining rods, lugs and brackets

Although a metal strap or iron band is not always necessary because of the joint's low torque, in some installations it will help to reduce tension on the hose when equipment is started up. This band should be installed, as shown above, so that the drum rotation pulls on the strap rather than the hose. The strap can be loosely connected to a short nipple added to the joint inlet, as shown in Diagram 4.

Torque restraining rods are often installed between joints on adjacent rolls to minimize hose flexing. Standard size torque restraining holes are supplied as an integral part of the joints casting. Holes sizes may change with the joint size, see Table 2 for recommendation rod O.D.

Table 2

Joint Size	Tie Rod Size	
	Pipe Size	Rod O.D.
1/2"	1/8"	3/8"
3/4"	1/8"	3/8"
1"	1/8"	3/8"
1-1/4"	1/4"	9/16"
1-1/2"	1/4"	9/16"
2"	1/4"	9/16"
2-1/2"	3/8"	5/8"
3"	1/2"	3/4"

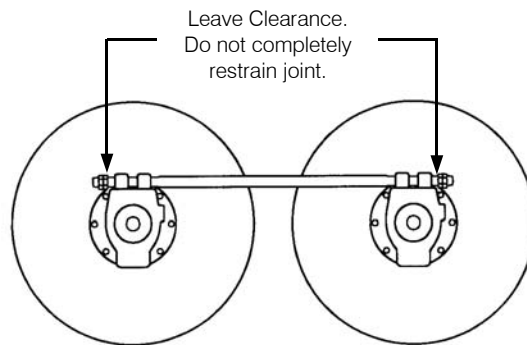

Torque restraining rods may be installed either horizontally, when rolls are alongside of each other, or vertically, when rolls are in stacked, above each other.

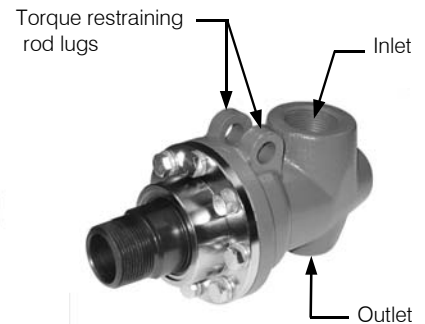
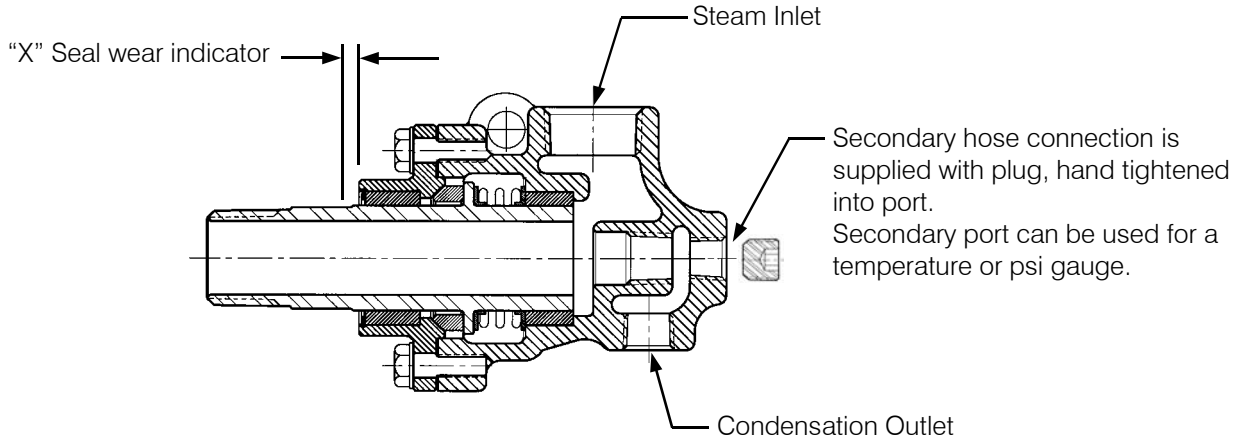

Table 1—Recommended Bend Radii

Hose Size	1"	1"	1-1/4"	1-1/4"	1-1/2"	1-1/2"	2"	2"	2-1/2"
Hose Min. Length	15"	20"	18"	25"	18"	28"	27"	32"	24"
Hose Bend	45°	90°	45°	90°	45°	90°	45°	90°	90°

Type "C" Maintenance



Preventive Maintenance.

By measuring dimension "X" (dimension from step on sleeve to the end cap) and referring to the dimensions supplied in Table 3, visual inspection periodically can determine the wear on the seals. When measured dimension exceeds "X" dimension, seals should be replaced, thus allowing for a scheduled maintenance shut down.

Table 3—"X" Recommended Seal replacement dimension

Joint Size	1/2"	3/4"	1"	1-1/4"	1-1/2"	2"	2-1/2"	3"
"X" Dimension	.19"	.19"	.25"	.25"	.25"	.31"	.25"	.25"

Repair Kits for Steam & water Joints.

Joint Size	Part Number
1/2"	10-27274-00
3/4"	10-27275-00
1"	10-24276-00
1-1/4"	10-27277-00
1-1/2"	10-27278-00
2"	10-27279-00
2-1/2"	10-27280-00
3"	10-27281-00

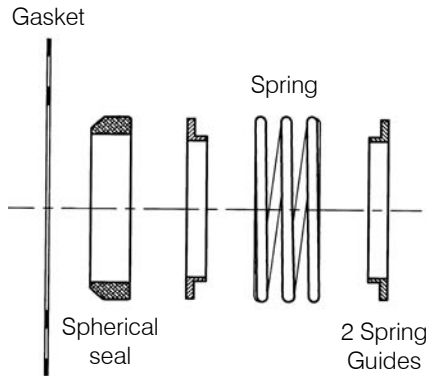

Hot Oil Joints.

Contact Barco for Hot Oil repair kits.

Many of the present oils used tend to "coke" at high temperatures and deposit material which settles in the joint and must be periodically cleaned to remove this residue. In addition, hot spots in the system may generate this material. Barco recommends a 40-60 micron filter to be installed upstream from that rotary joint to collect this material and prevent its introduction to the joint.

Barco International
 1100 Alexander Court
 Cary, IL 60013-1892
 Phone: (847) 516-0900
 Fax: (847) 516-5590



A DIVISION OF MARISON INDUSTRIES