

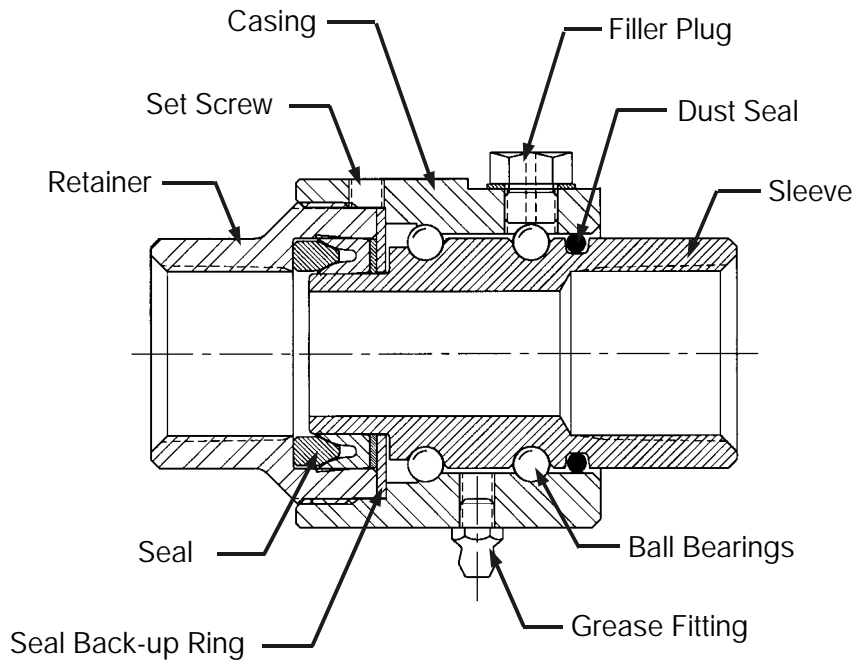

5200 Series Ball Bearing Plane Swivel Joints

Disassembly and Assembly Instructions



Disassembly

1. Loosen setscrew which is provided to prevent the retainer from loosening in relation to the casing during the swiveling motion of the joint in it's application.
2. Hold the casing and turn the retainer (right-hand thread) until the two parts are separated.

Note : the seal assembly and the seal back-up ring may remain in the retainer or both parts may remain on the sleeve. To replace only the seal, no further disassembly is necessary.

3. Removal of the ball bearings
 - A. Remove the metal filler plug.
 - B. The ball bearings in this race will then drop out if the sleeve is rotated slowly. It is sometimes necessary to dilute the bearing grease to accomplish this.
 - C. When all the ball bearings are removed from this race, the sleeve can then be pushed through the casing which will allow the ball bearings in the other race to drop out. The joint will then be completely disassembled.
 - D. The dust seal O-ring in the sleeve can then be easily removed and replaced if necessary.

Assembly on reversed side

Assembly Instructions

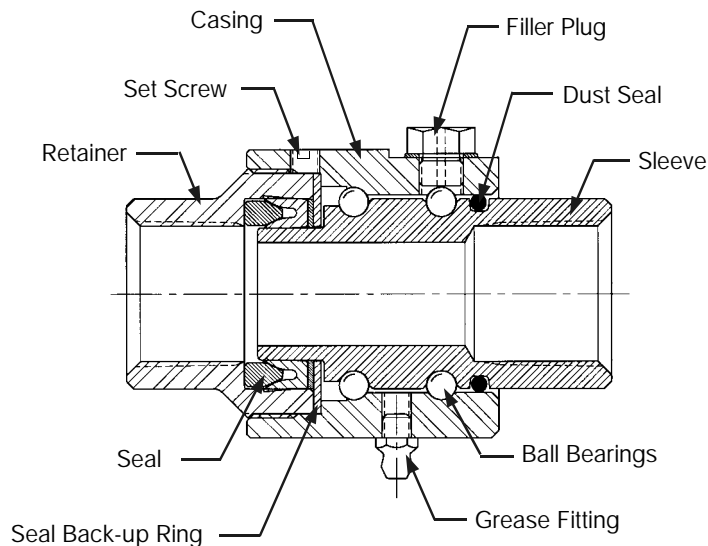

Figure 1.

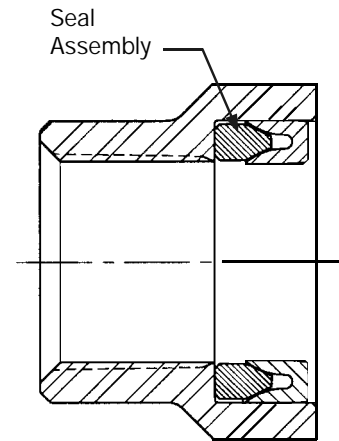

Figure 2.

Assembly

Note: After thoroughly cleaning and examining all parts to ascertain whether or not they have to be replaced as a result of excessive wear, the joint should be assembled in the following manner:

1. Lightly lubricate O-ring dust seal with Mobilgrease XHP 222, or equivalent grease. Insert O-ring dust seal into sleeve groove.
2. Insert sleeve into casing until the seal end of the sleeve is far enough through the casing so the inner ball race in the sleeve is exposed enough to drop the ball bearing into place.
3. When the full complement of ball bearings has been inserted into the inner race, the sleeve is drawn back into the casing until the ball bearings are into position against the race in the casing.
4. A full complement of ball bearing is then dropped through the ball filler hole in the casing. The required number of ball bearings needed to fill both races is shown on assembly drawing.

Caution: No more ball bearings than the number shown should be used.

5. Lubricate bearings using grease fitting. Use Mobilgrease XHP 222, or equivalent grease. Remove grease fitting, replace the metal filler plug and tighten.
6. Examine the lips of the seal for wear and replace if necessary. The seal assembly must be inserted into the retainer with the lips entering as shown in figure 2.

Caution: If the seal is placed on the sleeve instead of in the retainer, the outer seal lip may be damaged when assembling the casing to the retainer. Before inserting the seal into the retainer, a light coat of lubricant, such as Dow Corning Silicone or equivalent, should be spread on both the sealing surface in the retainer and on the sleeve.

7. The threads of the casing and the retainer should be lightly coated with a grease, such as Mobilgrease XHP 222, or equivalent. Place the seal back-up ring in the casing. The casing and retainer are then screwed together until the casing bottoms against the seal back-up ring. Tighten firmly.

